

MODEL: GT1280

SPECIFICATIONS

Maximum power output (2 Ohms): 500W x 4ch

RMS power Output: 200W x 4ch

Bridged Power Output: 1000W x 2ch

Frequency response: 9Hz - 50KHz

S/N Ratio: 103dB

Low Pass Crossover (Variable) 45Hz - 90Hz

High Pass Crossover (Fixed) 150Hz

Bass Boost (Variable) 0 - +18dB

Power Source Voltage: 14.4V

Ground: Negative

External dimensions: 236(W)x55(H)x520(D)mm

To engineers in charge of repair or inspection of our products.

Before repair or inspection, make sure to follow the instructions so that customers and Engineers in charge of repair or inspection can avoid suffering any risk or injury.

1. Use specified parts.

The system uses parts with special safety features against fire and voltage. Use only parts with equivalent characteristics when replacing them. The use of unspecified parts shall be regarded as remodeling for which we shall not be liable. The onus of product liability (PL) shall not be our responsibility in cases where an accident or failure is as a result of unspecified parts being used.

2. Place the parts and wiring back in their original positions after replacement or re-wiring. For proper circuit construction, use of insulation tubes, bonding, gaps to PCB, etc, is involved. The wiring connection and routing to the PWB are specially planned using clamps to keep away from heated and high voltage parts. Ensure that they are placed back in their original positions after repair or inspection. If extended damage is caused due to negligence during repair, the legal responsibility shall be with the repairing company.

3. Check for safety after repair. Check that the screws, parts and wires are put back securely in their original position after repair. Ensure for safety reasons there is no possibility of secondary problems around the repaired spots. If extended damage is caused due to negligence of repair, the legal responsibility shall be with the repairing company.

4. Caution in removal and making wiring connection to the parts for the automobile. Disconnect the battery terminal after turning the ignition key off. If wrong wiring connections are made with the battery connected, a short circuit and/or fire may occur. If extensive damage is caused due to negligence of repair, the legal responsibility shall be with the repairing company.

5. Cautions regarding chips.

Do not reuse removed chips even when no abnormality is observed in their appearance. Always replace them with new ones. (The chip parts include resistors, capacitors, diodes, transistors, etc). The negative pole of tantalum capacitors is highly susceptible to heat, so use special care when replacing them and check the operation afterwards.

6. Cautions in handling flexible PCB

Before working with a soldering iron, make sure that the iron tip temperature is around 270... Take care not to apply the iron tip repeatedly (more than three times) to the same patterns. Also take care not to apply the tip with force.

7. Turn the unit OFF during disassembly and parts replacement. Recheck all work before you apply power to the unit.

EXPLODED VIEW

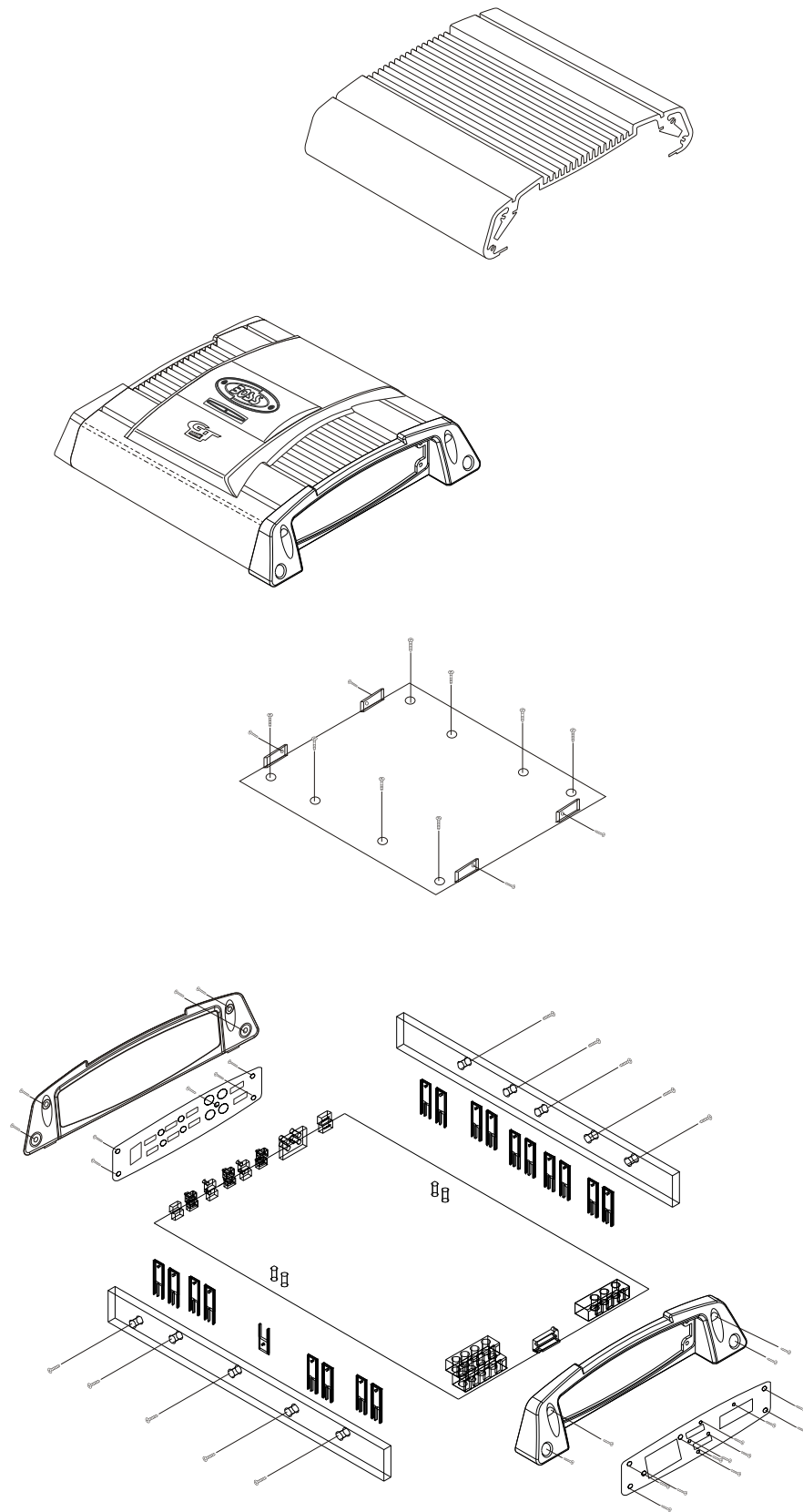

PRINTED CIRCUIT BOARD - 1

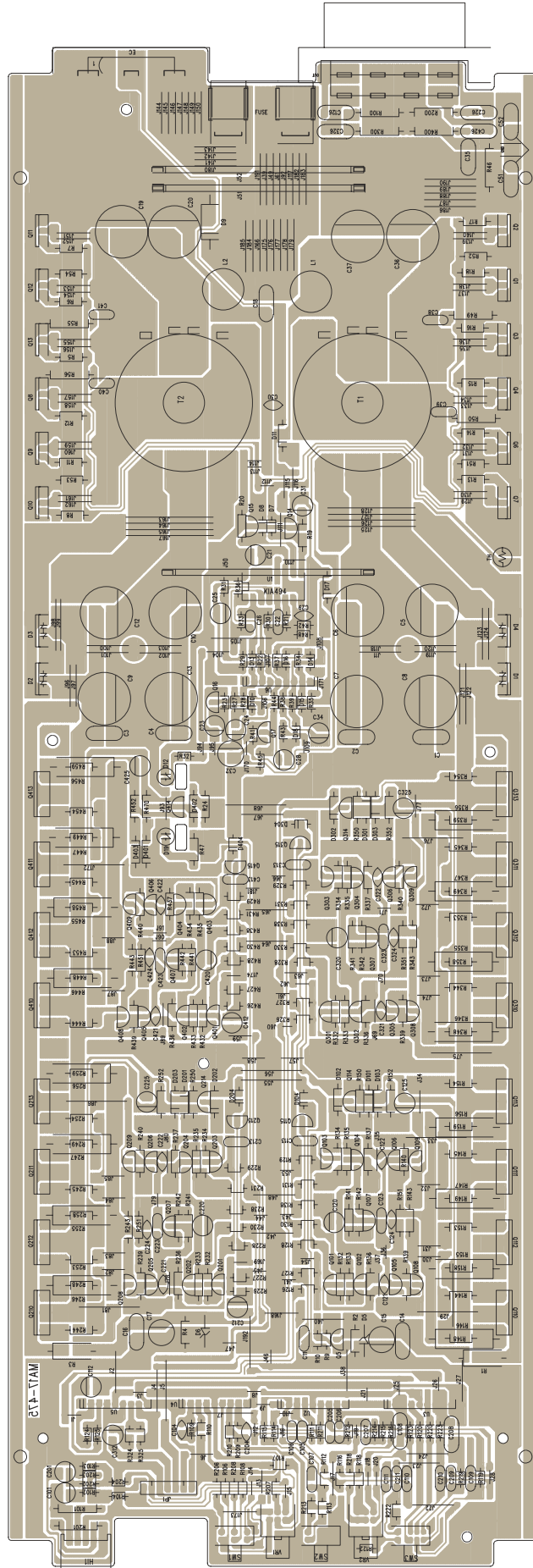

CIRCUIT DIAGRAM 1

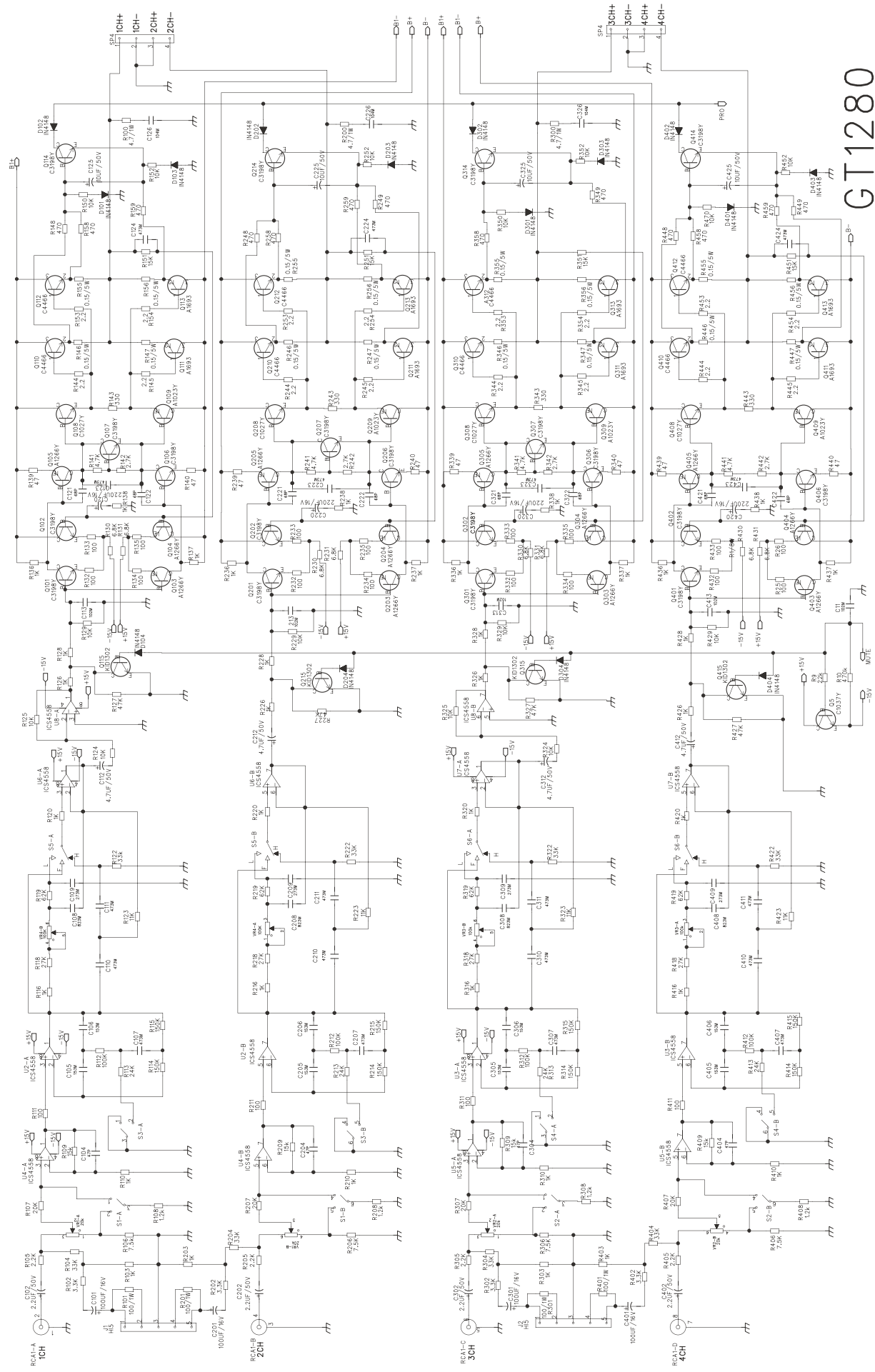

GT1280

CIRCUIT DIAGRAM 2

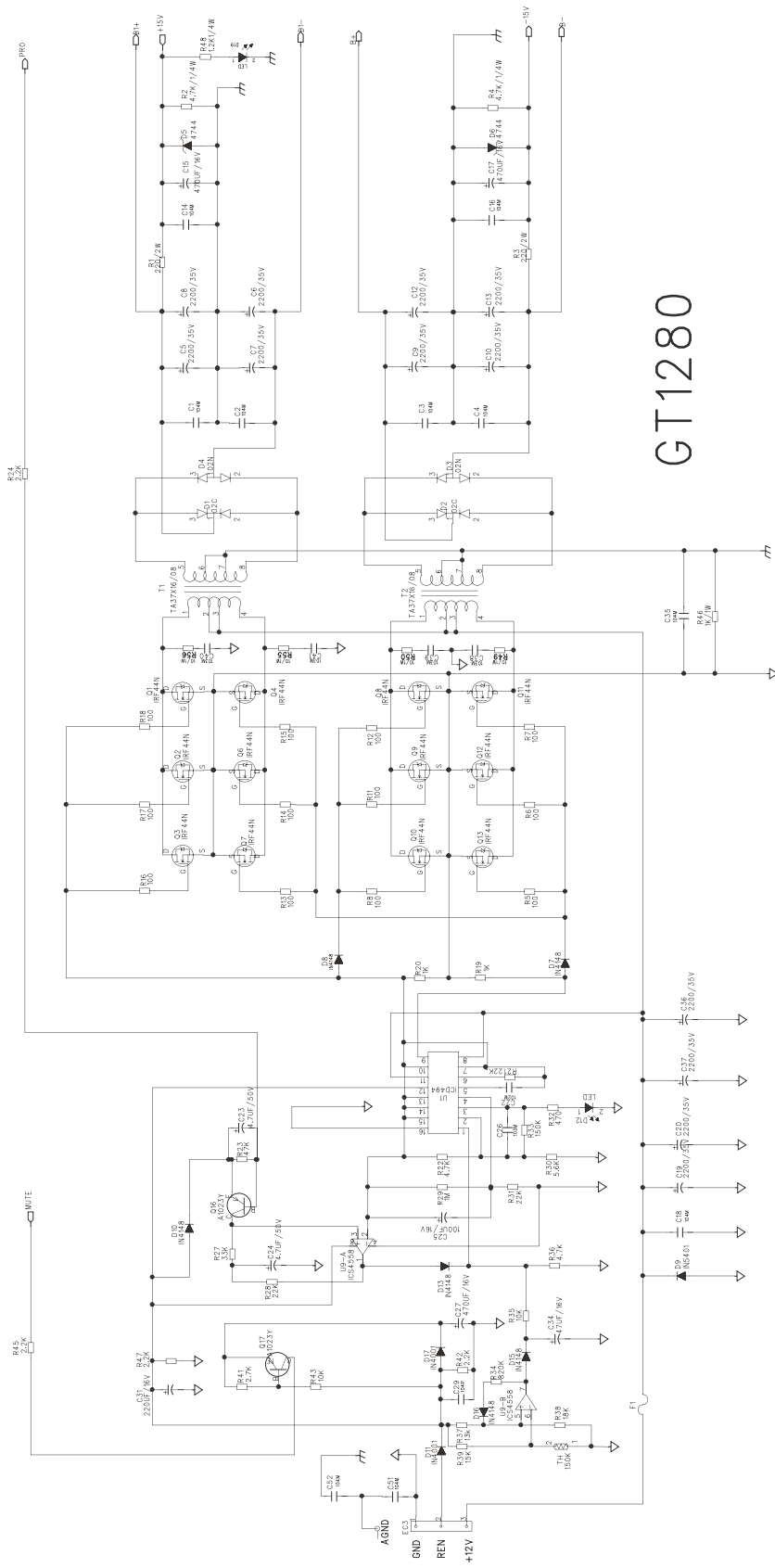

GT1280

PARTS LIST - 1

Part Number	desc	Location	qty
CR-40091X0-VOS00	4 Pin RCA Jack		1
CT-SOCKET0-3MA22	Power terminal		1
CT-SOCKET0-8MA17	Speaker terminal		1
CW-50000X0-H0025	High Input Jack		2
EC-C4104X0-Z6769	C Cap 0.1(Z)	C29,30	2
EC-C4220X0-D5050	C Cap 22PF(D)	C124,224,324,424	4
EC-C4470X0-Z5050	C Cap 47PF(Z)	C104,204,304,404	4
EC-C4680X0-J5050	C Cap 68PF(J)	C121,122,221,222,321,322,421,422	8
EC-E2107X0-M50A1	E Cap 100UF/16	C25,28,101,201,301,401	6
EC-E2227X0-M63A1	E Cap 220UF/16	C21,27,120,220,320,420,31	7
EC-E2476X0-M50A1	E Cap 47UF/16V	C34	1
EC-E2477X0-MA0A3	E Cap 470UF/16	C15,17	2
EC-E4106X0-M50A1	E Cap 10UF/50V	C125,225,325,425	4
EC-E4225X0-M50A1	E Cap 2.2UF/50	C102,202,302,402	4
EC-E4475X0-M50A1	E Cap 4.7UF/50	C23,24,112,212,312,412	6
EC-E6228X0-MA3B5	E Cap 2200/35V	C5~10,12,13,19,20,36,37	12
EC-M5102X0-J5590	Mylar Cap 0.001	C11,22,113,313,413,213	6
EC-M5103X0-J5590	Mylar Cap 0.01	C26,38,39,40,41	5
EC-M5104X0-JA0A3	Mylar Cap 0.1	C1~4,14,16,18,35,51,52,126,226,326,426	14
EC-M5153X0-J5785	Mylar Cap 0.015	C105,106,205,206,305,306,405,406	8
EC-M5273X0-J66A1	Mylar Cap 0.027	C109,209,309,409	4
EC-M5473X0-J80A1	Mylar Cap 0.047	C107,110,111,207,210,211,307,310,311,407,410,411,123,223,323,423	16
EC-M5823X0-K0000	Mylar Cap 0.082J	C108,208,308,408	4
ED-R2502C0-H0000	Diode ESAC25-02C	D1,2	2
ED-R2502N0-H0000	Diode ESAC25-02N	D3,4	2
ED-R4001X0-H0000	Diode IN-4001	D11,17	2
ED-R5401X0-H0000	Diode IN-5401	D9	1
ED-S4148X0-H0000	Diode IN-4148	D7,8,10,13~16,18,101~104,201~204,301~304,401~404	24
ED-Z15VXX0-H4744	ZENER IN4744	D5,6	2
EE-R225X70-76002	LED Red 2.5X7MM		1
EE-R525X70-76002	LED Green 2.5X7MM	D12	1
EO-IMA7475-VXXX6	Transformer		2
EO-VMA924X-V8025	coil		2
ER-HG153X0-HXXXX	THERMISTOR 150K		1
ER-OG022X0-H2526	Resistor 2.2 1/4W	R144,145,153,154,244,245,253,254,344,345,353,354,444,445,453,454	16

PARTS LIST - 2

Part Number	desc	Location	qty
ER-OG047X0-HA04C	Resistor 4.7 1W	R100,200,300,400	4
ER-OG100X0-HA04C	Resistor 10 1W	R56,55,49,50	4
ER-OG101X0-H1214	Resistor 100 1/8W	R45,111,211,311,411	5
ER-OG101X0-H2526	Resistor 100 1/4W	R5~8,11~18,132~135,232~235,332~335,432~435	28
ER-OG101X0-HA04C	Resistor 100 1W	R101,201,301,401	4
ER-OG102X0-H1214	Resistor 1K 1/8W	R44,103,110,116,120,126,128,138,203,210,216,220,226,228,238,	29
		303,310,316,320,326,000,000,000,000,000,000,000,000,000,000	
ER-OG102X0-H2526	Resistor 1K 1/4W	R19,20,136,137,236,237,336,337,436,437	10
ER-OG102X0-HA04C	Resistor 1K 1W	R46	1
ER-OG103X0-H1214	Resistor 10K 1/8W	R35,43,109,124,125,129,209,229,309,324,325,329,409,429	22
ER-OG103X0-H2526	Resistor 10K 1/4W	R150,152,250,252,350,352,452,470	8
ER-OG104X0-H1214	Resistor 100K 1/8W	R112,212,312,412	4
ER-OG105X0-H1214	Resistor 1M 1/8W	R29	1
ER-OG123X0-H1214	Resistor 12K 1/8W	R123,223,323,423	4
ER-OG123X0-H2526	Resistor 12K 1/4W	R47	1
ER-OG152X0-H1214	Resistor 1.5K 1/8W	R108,208,308,408	4
ER-OG153X0-H1214	Resistor 15K 1/8W	R37,39	2
ER-OG153X0-H2526	Resistor 15K 1/4W	R151,251,351,451	4
ER-OG154X0-H1214	Resistor 150K 1/8W	R33,114,115,214,215,314,315,414,415	9
ER-OG183X0-H1214	Resistor 18K 1/8W	R38	1
ER-OG203X0-H1214	Resistor 20K 1/8W	R107,207,307,407	4
ER-OG221X0-H1214	Resistor 220 1/8W	R38,39	2
ER-OG221X0-H2526	Resistor 220 1/4W	R51,52,53,54	4
ER-OG222X0-H1214	Resistor 2.2K 1/8W	R42,105,205,305,405,48	6
ER-OG222X0-H2526	Resistor 2.2K 1/4W	R24	1
ER-OG223X0-H1214	Resistor 22K 1/8W	R21,28,31	3
ER-OG243X0-H1214	Resistor 24K 1/8W	R113,213,313,413	4
ER-OG272X0-H1214	Resistor 2.7K 1/8W	R41	1
ER-OG272X0-H2526	Resistor 2.7K 1/4W	R142,242,342,442	4
ER-OG273X0-H1214	Resistor 27K 1/8W	R118,218,318,418	4
ER-OG331X0-H2526	Resistor 330 1/4W	R143,243,343,443	4
ER-OG332X0-H1214	Resistor 3.3K 1/8W	R102,202,302,402	4
ER-OG333X0-H1214	Resistor 33K 1/8W	R9,10,27,104,122,204,222,304,322,404,422	11
ER-OG470X0-H2526	Resistor 47 1/4W	R139,140,239,240,339,340,439,440	8
ER-OG471X0-H1214	Resistor 470 1/8W	R32	1

PARTS LIST - 3

Part Number	desc	Location	qty
ER-OG471X0-H2526	Resistor 470 1/4W	148,149,158,159,248,249,258,259,348,349,358,359,448,449,458,459	16
ER-OG471X0-HA04C	Resistor 470 1W	R1,3	2
ER-OG472X0-H1214	Resistor 4.7K 1/8W	R22,36	2
ER-OG472X0-H2526	Resistor 4.7K 1/4W	R2,4,141,241,341,441	6
ER-OG473X0-H1214	Resistor 47K 1/8W	R23,127,227,327,427	5
ER-OG562X0-H1214	Resistor 5.6K 1/8W	R30	1
ER-OG623X0-H1214	Resistor 62K 1/8W	R119,219,319,419	4
ER-OG682X0-H1214	Resistor 6.8K 1/8W	R130,131,230,231,330,331,430,431	8
ER-OG752X0-H1214	Resistor 7.5K 1/8W	R106,206,306,406	4
ER-OG824X0-H1214	Resistor 820K 1/8W	R34	1
ER-WG.15X0-HXXXX	Resistor 0.15 5W	R146,147,155,156,246,247,255,256,346,347,355,356,446,447,455,456	16
ES-S2219X0-H0006	Switch JSS2219		4
ES-S23D29X-V0098	Switch SK23D39		2
ET-C1023X0-PY000	Transistor KTA1023-Y	Q14~16,109,209,309,409	7
ET-C1027X0-NY000	Transistor KTC1027-Y	Q5,108,208,308,408	5
ET-C1266X0-PY000	Transistor A1266Y	Q103~105,203~205,303~305,403~405,17	13
ET-C1302K0-N0000	Transistor KTD-1302	Q115,215,315,415	4
ET-C1693X0-PY000	Transistor 2SA1693	Q111,113,211,213,311,313,411,413	8
ET-C3198K0-NY000	Transistor KTC3198-Y	Q101,102,106,107,114,201,202,206,207,214,301,302,306,307,314, 401,402,406,407,414,	20
ET-C4466X0-NY000	Transistor 2SC4466	A312,Q110,112,210,212,310,410,412	8
ET-FFZ44X0-X0000	Mosfet IRFZ 44N	Q1~4,6~13	12
II-4558LX0-V0008	IC NJM4558L	U2~6,IC7,8,9	8
II-494P0X0-H0016	IC KIA-494AP	U1	1
VR-BN104X0-V0A26	VR 100KB T12		2
VR-BN203X0-V0A26	VR 20KB T12		2